

Direktantrieb

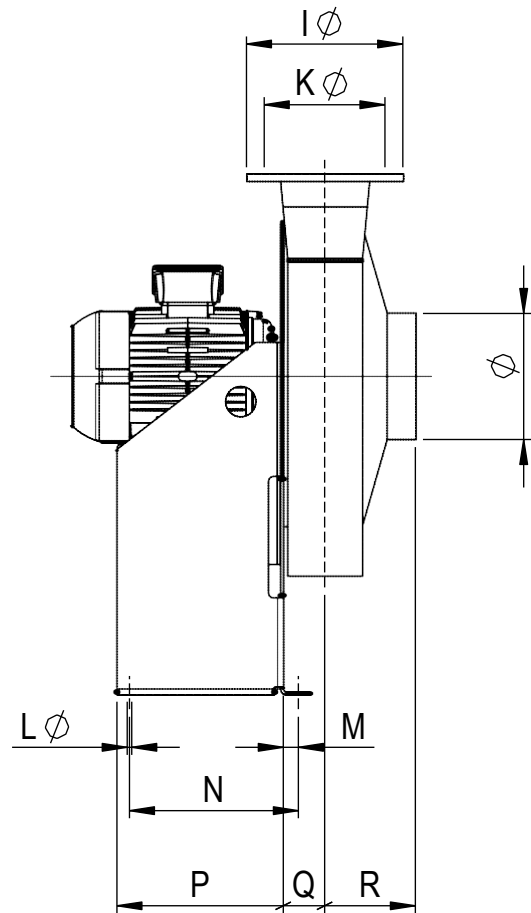

| CHVS | 63  | 90  | 125  | 160  | 200  | 250 |
|------|-----|-----|------|------|------|-----|
| A    | 309 | 317 | 327  | 338  | 351  | 361 |
| B    | 275 | 281 | 289  | 298  | 307  | 318 |
| C    | 311 | 323 | 339  | 356  | 375  | 395 |
| D    | 307 | 311 | 315  | 320  | 327  | 327 |
| E    | 630 | 630 | 630  | 630  | 630  | 630 |
| F    | 400 | 400 | 400  | 400  | 400  | 400 |
| G    | 545 | 545 | 545  | 545  | 545  | 545 |
| H    | 619 | 619 | 619  | 619  | 619  | 619 |
| I Ø  | 120 | 150 | 185  | 220  | 260  | 310 |
| K Ø  | 63  | 90  | 125  | 160  | 200  | 250 |
| L Ø  | 9   | 9   | 9    | 9    | 9    | 9   |
| M    | 30  | 30  | 30   | 30   | 30   | 30  |
| N    | 335 | 335 | 335  | 335  | 335  | 335 |
| P    | 330 | 330 | 330  | 330  | 330  | 330 |
| Q    | 61  | 64  | 67.5 | 71.5 | 75.5 | 82  |
| R    | 180 | 180 | 180  | 180  | 180  | 180 |

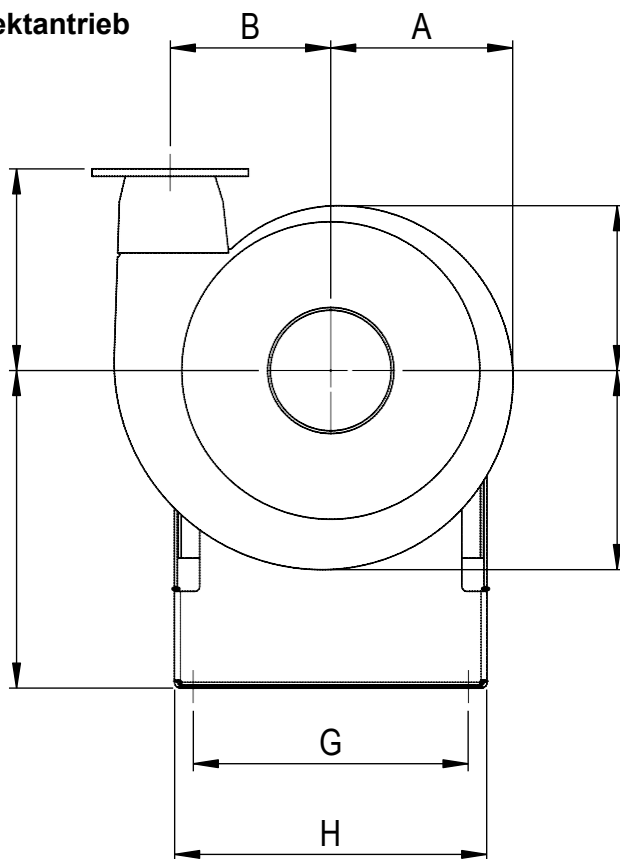
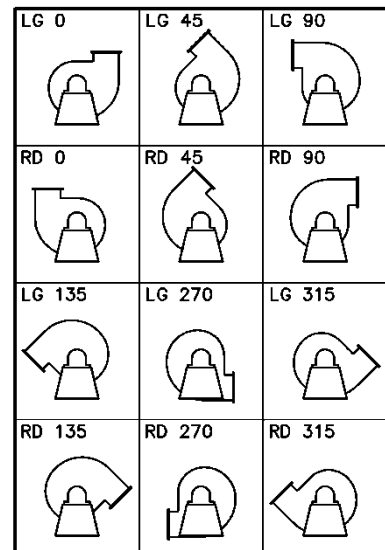

Keilriemenantrieb

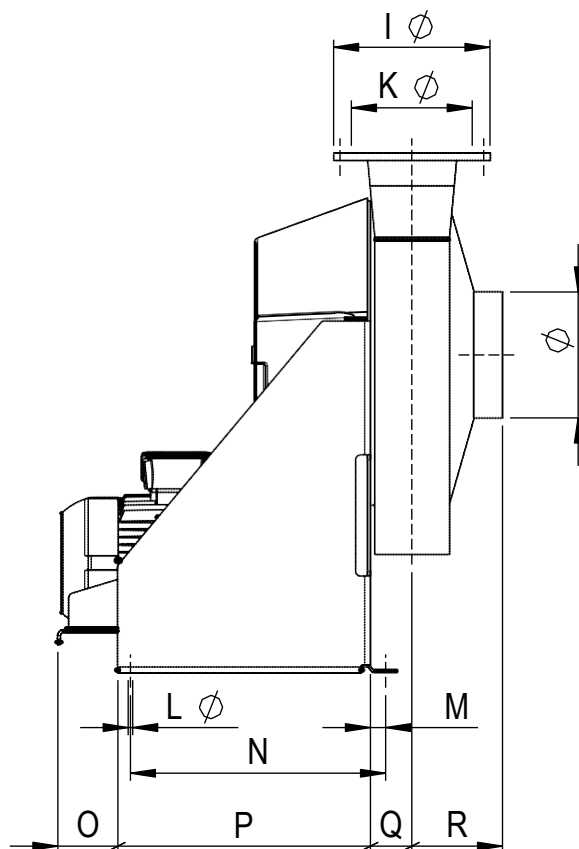
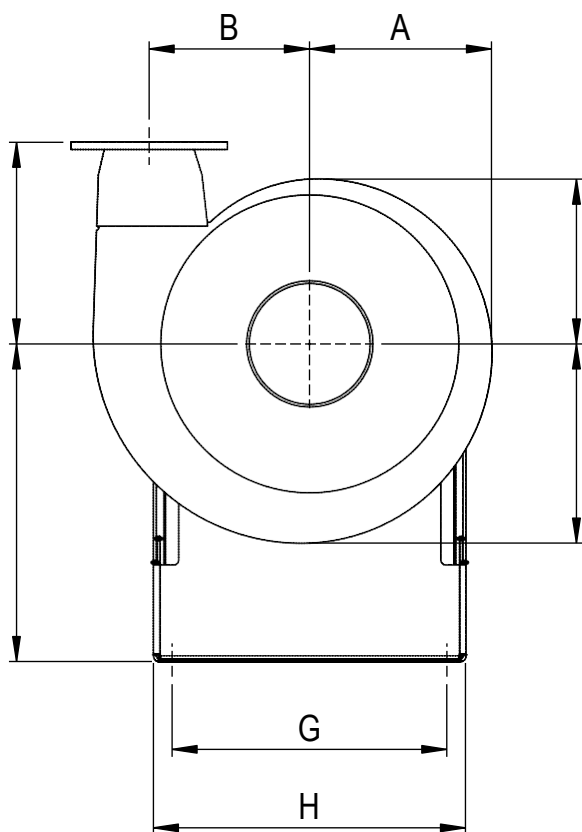

| CHVS | 63  | 90  | 125  | 160  | 200  | 250 |
|------|-----|-----|------|------|------|-----|
| A    | 309 | 317 | 327  | 338  | 351  | 361 |
| B    | 275 | 281 | 289  | 298  | 307  | 318 |
| C    | 311 | 323 | 339  | 356  | 375  | 395 |
| D    | 307 | 311 | 315  | 320  | 327  | 327 |
| E    | 630 | 630 | 630  | 630  | 630  | 630 |
| F    | 400 | 400 | 400  | 400  | 400  | 400 |
| G    | 545 | 545 | 545  | 545  | 545  | 545 |
| H    | 619 | 619 | 619  | 619  | 619  | 619 |
| I Ø  | 120 | 150 | 185  | 220  | 260  | 310 |
| K    | 63  | 90  | 125  | 160  | 200  | 250 |
| L    | 9   | 9   | 9    | 9    | 9    | 9   |
| M    | 30  | 30  | 30   | 30   | 30   | 30  |
| N    | 506 | 506 | 506  | 506  | 506  | 506 |
| O    | 119 | 119 | 119  | 119  | 119  | 119 |
| P    | 501 | 501 | 501  | 501  | 501  | 501 |
| Q    | 61  | 64  | 67.5 | 71.5 | 75.5 | 82  |

